

Features

- 2:1/4:1 Wide Input Range
- Operating Temperature Range: -45°C~105°C
- Approved to CE, RoHS & REACH
- Safety Standards to IEC/EN 62368-1 & EN 50155
- Efficiency up to 93%
- EMI Class A & B
- Single Output 12~48V DC



Certified to UKCA, CE, RoHS, REACH & EN 62368-1/IEC 62368-1/EN 50156 Standards and complies with Efficiency Regulations. These are primarily used in ITE, Audio & Video, Railway Industries and customised solutions are available upon request.

Part Number Structure

| 28MQB | - | 028 | | 050 | - | S | - | P | - | B | 75 |
|----------------|---|---------------------|--|----------------------|---|-------------------|---|-----------------------|---|-----------------------|------|
| Series Name | | Input Voltage (VDC) | | Output Voltage (VDC) | | Output Quantity | | Remote control option | | Shape | Watt |
| Mercury series | | 028 : 9-75 | | 050 : 5 | | S : Single | | P: Positive logic | | B : Base Plate | 50 |
| Quarter | | 054 : 14-154 | | 120 : 12 | | | | N: Negative logic | | | 75 |
| Brick | | | | 150 : 15 | | | | | | | |
| | | | | 240 : 24 | | | | | | | |
| | | | | 120 : +12 | | D : Dual | | | | | |
| | | | | 150 : +15 | | | | | | | |
| | | | | 240 : +24 | | | | | | | |

Models

| Model | Input | | | Output | | | Efficiency Typ.(%) | Max Capacitive load μF |
|------------------------|-------------|---------|-------------|----------------|----------------|--------------|-----------------------|-------------------------------------|
| | Voltage (V) | | Current (A) | Voltage (V) | Current (A) | Power (W) | | |
| | Range | Nominal | Full load | | | | | |
| 28MQB028050-S-□-B50-IP | 9-75 | 28 | 1.98 | 5 | 10.0 | 50 | 90 | 1800 |
| 28MQB028120-S-□-B50-IP | 9-75 | 28 | 2.01 | 12 | 4.2 | 50 | 89 | 5000 |
| 28MQB028150-S-□-B50-IP | 9-75 | 28 | 2.01 | 15 | 3.3 | 50 | 89 | 3200 |
| 28MQB028240-S-□-B50-IP | 9-75 | 28 | 2.01 | 24 | 2.1 | 50 | 89 | 1200 |
| 28MQB028120-D-□-B50-IP | 9-75 | 28 | 2.01 | +12 | 2.1 | 50 | 89 | 1000 |
| 28MQB028150-D-□-B50-IP | 9-75 | 28 | 2.01 | +15 | 1.7 | 50 | 89 | 500 |
| 28MQB028240-D-□-B50-IP | 9-75 | 28 | 2.01 | +24 | 1.0 | 50 | 89 | 200 |
| 28MQB028050-S-□-B75-IP | 9-75 | 28 | 3.01 | 5 | 15 | 75 | 89 | 18000 |
| 28MQB028120-S-□-B75-IP | 9-75 | 28 | 3.04 | 12 | 6.25 | 75 | 88 | 5000 |
| 28MQB028150-S-□-B75-IP | 9-75 | 28 | 3.04 | 15 | 5 | 75 | 88 | 3200 |
| 28MQB028240-S-□-B75-IP | 9-75 | 28 | 3.04 | 24 | 3.125 | 75 | 88 | 1200 |
| 28MQB028120-D-□-B75-IP | 9-75 | 28 | 3.04 | +12 | 3.13 | 75 | 88 | 1000 |
| 28MQB028150-D-□-B75-IP | 9-75 | 28 | 3.04 | +15 | 2.5 | 75 | 88 | 500 |
| 28MQB028240-D-□-B75-IP | 9-75 | 28 | 3.04 | +24 | 1.56 | 75 | 88 | 200 |
| 28MQB054050-S-□-B50-IP | 14-154 | 54 | 1.03 | 5 | 10.0 | 50 | 90 | 18000 |
| 28MQB054120-S-□-B50-IP | 14-154 | 54 | 1.04 | 12 | 4.2 | 50 | 89 | 5000 |
| 28MQB054150-S-□-B50-IP | 14-154 | 54 | 1.04 | 15 | 3.3 | 50 | 89 | 3200 |
| 28MQB054240-S-□-B50-IP | 14-154 | 54 | 1.04 | 24 | 2.1 | 50 | 89 | 1200 |
| 28MQB054120-D-□-B50-IP | 14-154 | 54 | 1.04 | +12 | 2.1 | 50 | 89 | 1000 |
| 28MQB054150-D-□-B50-IP | 14-154 | 54 | 1.04 | +15 | 1.7 | 50 | 89 | 500 |
| 28MQB054240-D-□-B50-IP | 14-154 | 54 | 1.04 | +24 | 1.0 | 50 | 89 | 200 |
| 28MQB054050-S-□-B75-IP | 14-154 | 54 | 1.56 | 5 | 15 | 75 | 88 | 18000 |
| 28MQB054120-S-□-B75-IP | 14-154 | 54 | 1.58 | 12 | 6.25 | 75 | 88 | 5000 |
| 28MQB054150-S-□-B75-IP | 14-154 | 54 | 1.58 | 15 | 5 | 75 | 88 | 3200 |
| 28MQB054240-S-□-B75-IP | 14-154 | 54 | 1.58 | 24 | 3.125 | 75 | 88 | 1200 |
| 28MQB054120-D-□-B75-IP | 14-154 | 54 | 1.58 | +12 | 3.13 | 75 | 88 | 1000 |
| 28MQB054150-D-□-B75-IP | 14-154 | 54 | 1.58 | +15 | 2.5 | 75 | 88 | 500 |
| 28MQB054240-D-□-B75-IP | 14-154 | 54 | 1.58 | +24 | 1.56 | 75 | 88 | 200 |

Description

Ideal Power Multiple Output series - Quarter Brick converter is composed of Isolated, board-mountable, fixed switching frequency dc-dc converters that use synchronous rectification to achieve extremely high-power conversion efficiency. These DC-DC converter modules use advanced power processing, control, and packaging technologies to enhance the performance, flexibility, reliability, and cost effectiveness of mature power components. Each module is six-sided metal case enclosed to provide protection from the harsh environments seen in many industrial and transportation applications.

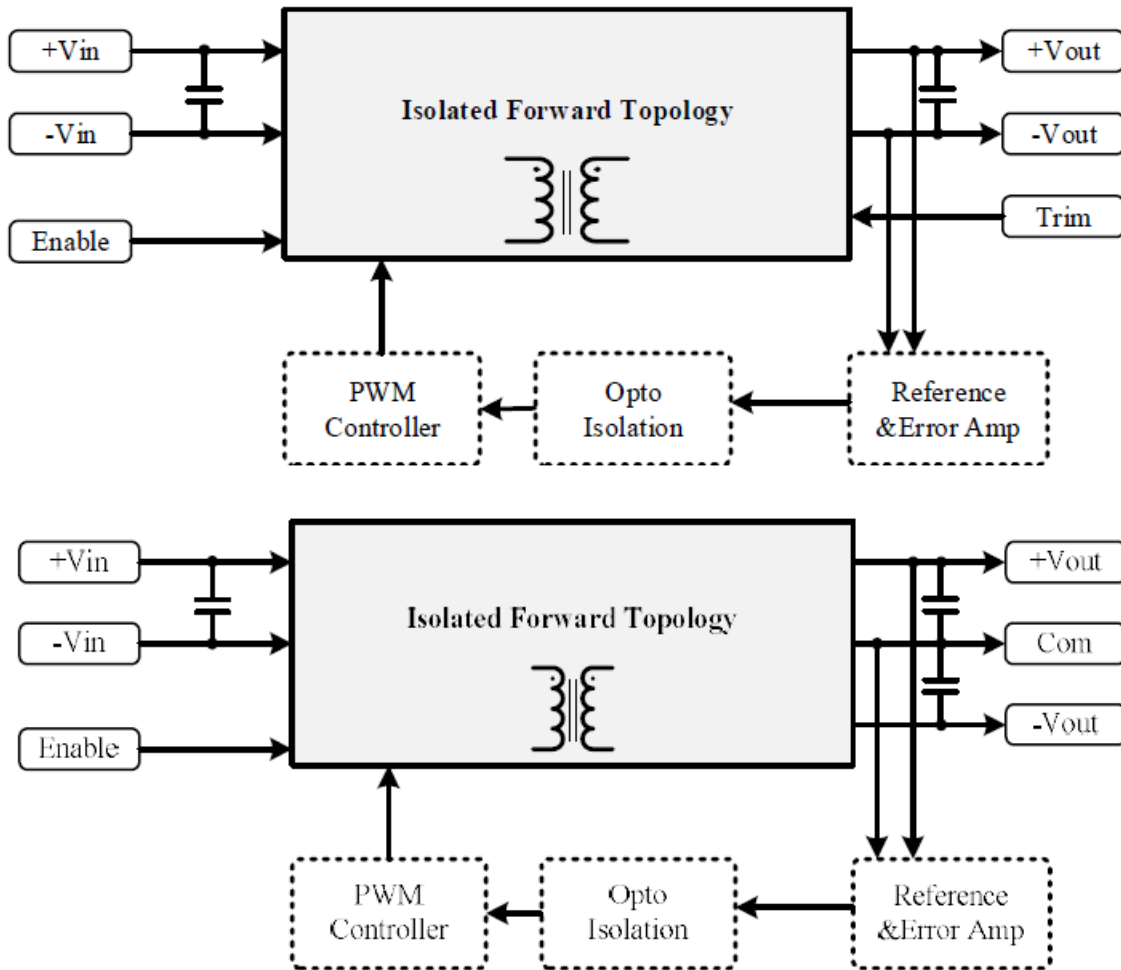

DC - DC

Input Data

| Parameter | Notes and Conditions | Min. | Typ. | Max. | Unit |
|--|--|-----------------------|----------|-----------|------|
| Transient Input Voltage Ranges | 28MQB028 models (100ms Max) 28MQB054 models (100ms Max) | -- | -- | 80 160 | VDC |
| Operating Input Voltage Ranges | 28MQB028 models 28MQB054 models | 9 14 | 28 54 | 75 154 | VDC |
| Under-Voltage Lockout Start up Voltage | 28MQB028 models 28MQB054 models | -- | -- | 9 14 | VDC |
| Under-Voltage Lockout Shutdown Voltage | 28MQB028 models 28MQB054 models | -- | 7 12 | -- | VDC |
| Enable Function Input | Positive logic ON OFF | Open Short or 0 ~ 1.2 | | | VDC |
| | Negative logic ON OFF | Short or 0 ~ 1.2 open | | | VDC |

Output Data

| Parameter | Notes and Conditions | Min. | Typ. | Max. | Unit |
|----------------------------|--|------|------|-------|--------|
| Output Voltage Accuracy | VNOM 50% Load | -- | -- | ±1.5 | % |
| Line Regulation | Low Line to High Line | -- | -- | ±0.3 | % |
| Load Regulation | 10% to 100% Load | -- | -- | ±0.5 | % |
| Ripple & Noise Voltage | Bandwidth 20MHz and with 1µF MLCC Output Capacitor | -- | 1.5 | -- | %Vpk- |
| Temperature Coefficient | -- | -- | -- | +0.04 | % / °C |
| Transient Recovery Time | 25% load step change | -- | 800 | -- | µSec |
| Transient Peak Deviation | $\Delta I_o / \Delta t = 2.5A/\mu s$ | -- | +2 | -- | %Vo |
| Start-Up Time | When use Enable Function | -- | 20 | -- | mSec. |
| Trimming Output Protection | VNOM 10% Load | -- | +10 | -- | % |
| Output power protection | VNOM 10% Load | -- | 120 | -- | % |
| Over Voltage Protection | VNOM | -- | 120 | -- | % |
| Minimum Load | Single output | 0 | -- | -- | % |
| | Dual Output | 0 | -- | -- | % |

General Specifications & Environmental Data

| Parameter | Notes and Conditions | Min. | Typ. | Max. | Unit |
|-----------------------------|----------------------------|--|------|------|--------|
| Switching frequency | V _{NOM} | -- | 220 | -- | kHz |
| Storage temperature range | All models | -60 | -- | 125 | C |
| Operating case temperature | All models | -45 | -- | 105 | m |
| Over temperature protection | All models, Auto. Recovery | -- | 110 | -- | C |
| Isolation Voltage | | | | | |
| Input to Output | All models, 1 Minute | -- | 2250 | -- | VDC |
| Input to Output to case | | | 1500 | | |
| Isolation Resistance | All models, | | | | |
| Input to Output | 500VDC, At 70%RH | 100 | -- | -- | MΩ |
| Isolation Capacitance | All models | | | | |
| Input to Output | | -- | 1500 | -- | pF |
| Humidity (non condensing) | All models | -- | -- | 95 | % |
| Calculated MTBF | BellCore-TR-332@ 50°C G.B | -- | 1 | -- | M HR |
| Weight | Shape-B | | 68 | | G (oz) |
| Dimensions | Shape-B | 2.36" x 1.57" x 0.49" (60.0 x 40.0 x 12.4mm) | | | |
| Case Material | Aluminium | | | | |

Standards Compliance

| Parameter | Standard | Test conditions | Performance criteria |
|--------------------------|-------------|---|----------------------|
| Environmental Compliance | Reach; RoHS | -- | Pass |
| EMI | EN55032 | -- | Class A / Class B |
| ESD | EN61000-4-2 | ±4 kV Air Discharge ±4 kV Contact Discharge | Crit. A |
| Radiated Immunity | EN61000-4-3 | Level 2, 3 V/m | Crit. A |
| Fast Transient | EN61000-4-4 | ±2 kV Applied | Crit. A |
| Surge | EN61000-4-5 | ±2 kV Applied | Crit. A |
| Conducted Immunity | EN61000-4-6 | Level 2, 3 V rms | Crit. A |

It is recommended to protect the input by fuses or other protection devices.

Modules could meet EN55022 Class A and Class B standard with external components.

The information and specifications contained in this data sheet are believed to be correct at time of publication. All specifications are subject to change without notice. No rights under any patent accompany the sale of any such products or information contained herein

Mechanical Drawings & Pin Assignment

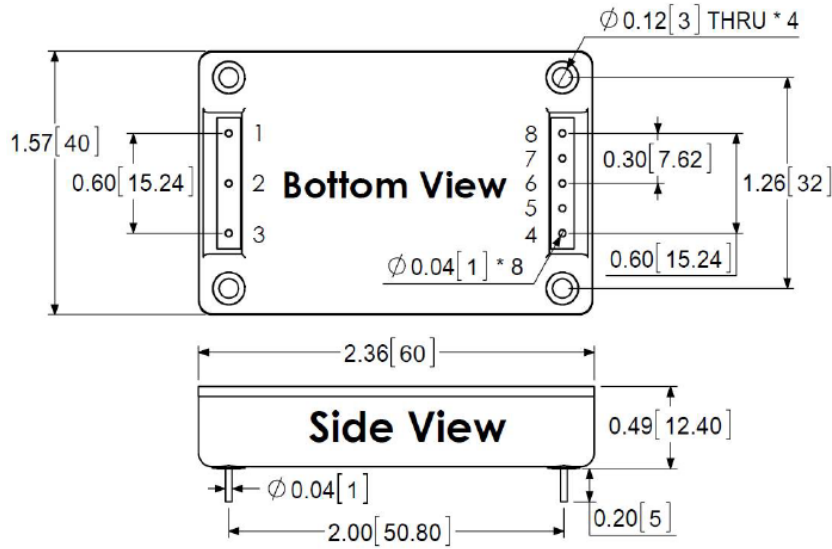

| Pin# | Single | Dual |
|------|--------|--------|
| 1 | -Vin | -Vin |
| 2 | Enable | Enable |
| 3 | +Vin | +Vin |
| 4 | +Vout | +Vout |
| 5 | TrNA | NA |
| 6 | Trim | Common |
| 7 | NA | NA |
| 8 | -Vout | -Vout |

Note:
All pins are 0.040" (1.02mm)
Pin Material: Copper Alloy
Pin Plating: Gold
Dimensions in inches [mm]
Tolerances: .XX±0.02 [.X±0.5mm]

Conducted EMI

Input terminal value (typ.) 28MQB028240-S-P-B50-IP @Vin = 28VDC, Iout = 2.08A

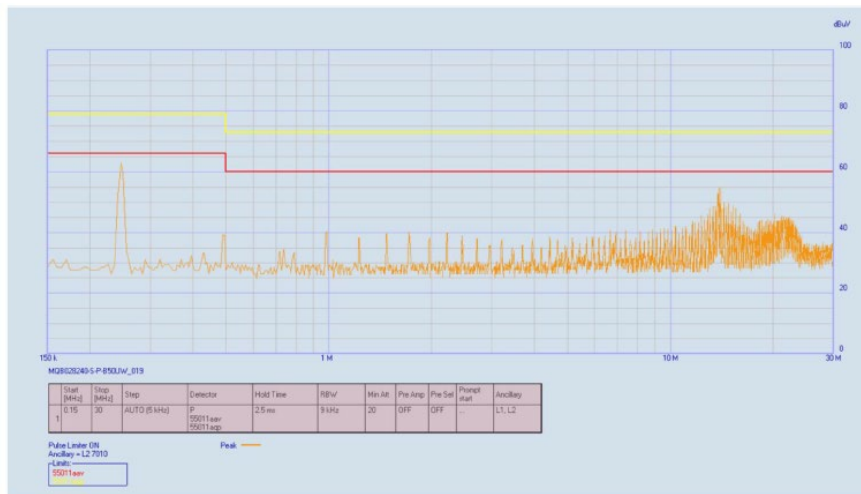

Characteristic Curves

Testing conditions are at typical input, $T_a=+25^{\circ}\text{C}$, full load (horizontal mount) Unless otherwise indicated

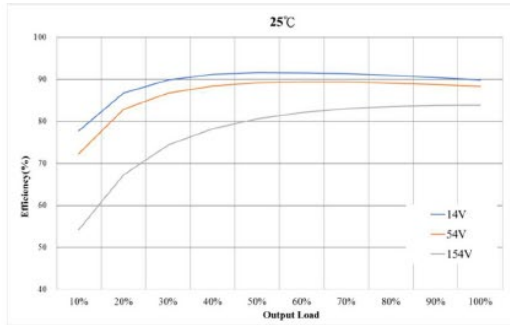

Figure 1 : Efficiency at Minimum, Nominal and Maximum Input Voltages VS. Output Load.

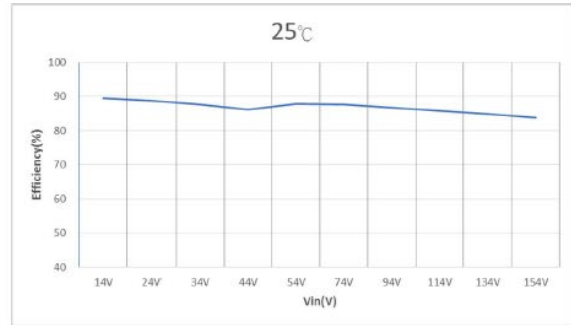

Figure 2 : Efficiency VS. Input Voltages at 100% rated power

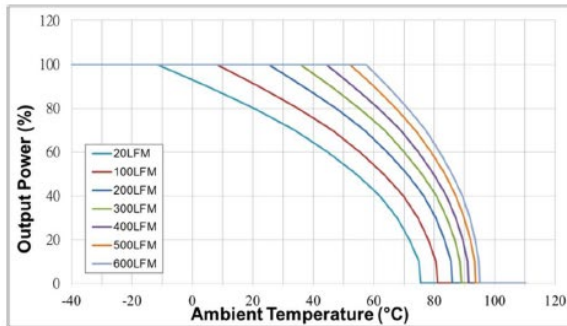

Figure 3 : Ambient Temperature VS. Output Power Derating Curves (Note: 20LFM = Free Air)

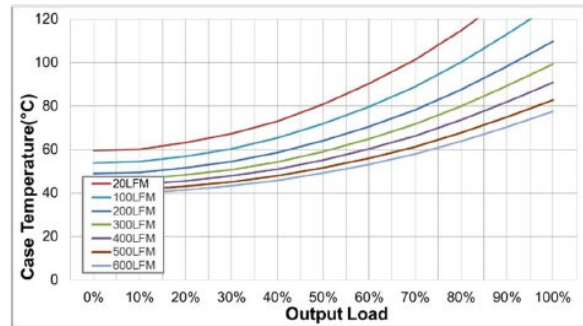

Figure 4 : Case Temperature VS. Output rated Power (Note: 20LFM = Free Air)

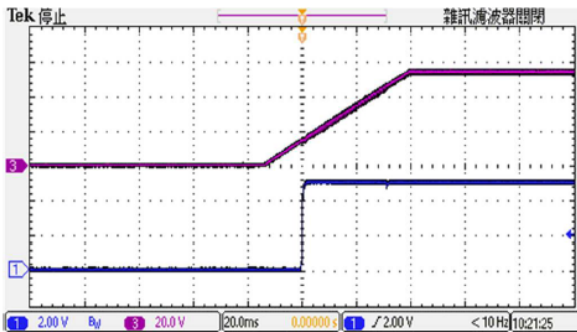

Figure 5 : CH1 = Vout, CH3 = Nominal Input Typical Start-up waveform at Full load.

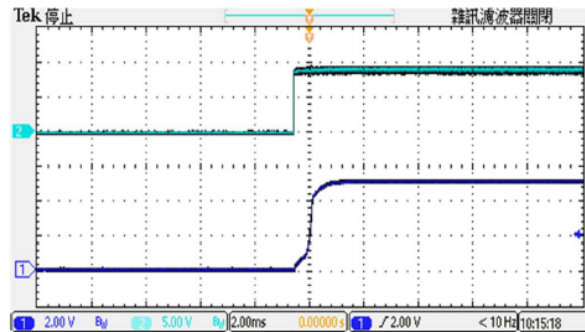

Figure 6 : CH1 = Vout, CH3 = Enable Pin Typical Start-up waveform. Input voltage pre-applied

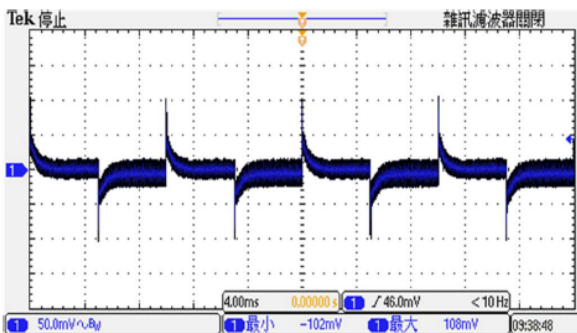

Figure 7 : Transient Response at Output step load (V_{in} : Typical, 50~75% of output current; $\Delta I_o/\Delta t = 1\text{A}/\mu\text{S}$)

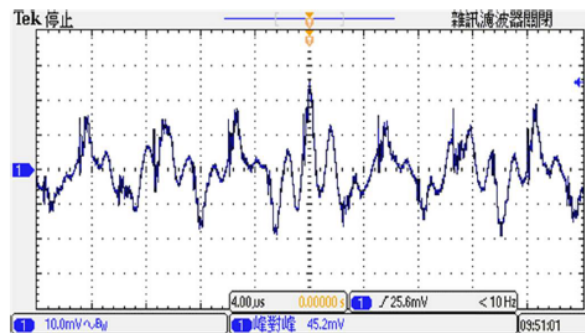

Figure 8 : Output Voltage Ripple & Noise at full load. (V_{in} : Typical, With Output Capacitor to add 1uF MLCC)

Characteristic Curves

Only the single output converters have a trim function. That allows users to adjust the output voltage from +10% to -10%, please refer to the trim table that follow for details. Adjustments to the output voltage can be used with a simple fixed resistor as shown in Figures 1 and 2. A single fixed resistor can increase or decrease the output voltage depending on its connection.

Note:

✧ Trim adjustments higher than the specified range can have an adverse effect on the converter's performance and are not recommended.

✧ If the trim function is not used, leave the trim pin open.

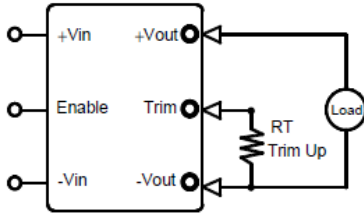

Figure 1. Trim Connections To increase Output Voltages Using Fixed Resistors

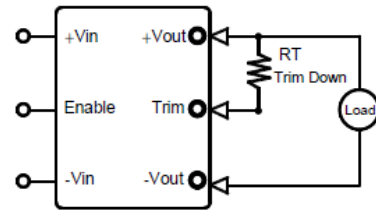

Figure 2. Trim Connections To Decrease Output Voltages Using Fixed Resistors

Trim up resistor value(KΩ)

| Vout | 1% | 2% | 3% | 4% | 5% | 6% | 7% | 8% | 9% | 10% |
|------|-------|-------|-------|------|------|------|------|------|------|-----|
| 5 | 112.2 | 51.1 | 30.7 | 20.5 | 14.4 | 10.4 | 7.5 | 5.3 | 3.6 | 2.2 |
| 12 | 267.8 | 121.9 | 73.3 | 49.0 | 34.4 | 24.6 | 17.7 | 12.5 | 8.4 | 5.2 |
| 15 | 332.9 | 151.5 | 91 | 60.7 | 42.6 | 30.5 | 21.8 | 15.4 | 10.3 | 6.3 |
| 24 | 516.2 | 232.6 | 138.1 | 90.8 | 62.4 | 43.5 | 30 | 19.9 | 12 | 5.7 |

Trim down resistor value(KΩ)

| Vout | -1% | -2% | -3% | -4% | -5% | -6% | -7% | -8% | -9% | -10% |
|------|-------|-------|-------|-------|-------|------|------|------|------|------|
| 5 | 139.8 | 63.5 | 38.1 | 25.4 | 17.8 | 12.7 | 9.0 | 6.3 | 4.2 | 2.5 |
| 12 | 342.5 | 155.9 | 93.7 | 62.6 | 44.0 | 31.5 | 22.7 | 16.0 | 10.8 | 6.7 |
| 15 | 454.5 | 205 | 125.8 | 84.7 | 60.1 | 43.6 | 31.9 | 23.1 | 16.2 | 10.7 |
| 24 | 797.5 | 366.1 | 222.3 | 150.4 | 107.3 | 78.5 | 58 | 42.6 | 30.6 | 21 |

Enable Control Function

The primary-side, Enable Control function can be specified to operate with either positive or negative polarity. Positive-polarity devices are enabled when the enable pin is left open or is pulled high. See "Enable Function Input". Positive-polarity devices are disabled when the enable pin is pulled low (under +1.0V with respect to -input). Negative-polarity devices are off when the enable pin is high/open and on when the enable pin is pulled low. See Figure 3.

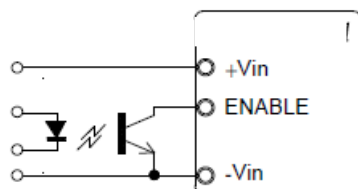

Figure 3. Driving the Enable Control pin

Output Ripple Noise

The two copper strips simulate real-world PCB impedances between the converter and its load. Scope measurements should be made using BNC connectors or the probe ground should be less than 1/2 inch and soldered directly to the fixture.

All external capacitors should have appropriate voltage ratings and be located as close to the converter as possible. Temperature variations for all relevant parameters should be taken into consideration. The most effective combination of external I/O capacitors will be a function of line voltage and source impedance, as well as load and layout conditions. See Figure 4

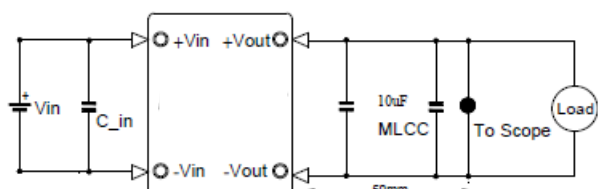

Figure 4. Measuring Output Ripple/Noise(20MHz bandwidth)